



GR-512/GR-512W



Slim : Unique 255mm width refined stainless steel cabinet provides spacious and comfortable 550mm ergonomic passages.

Safe : Panel will automatically close upon detection of unauthorized access. It fulfills anti-tailgating detection output and passage security level setting.

Fast : High passage speed, up to 40 people per minute.

Quiet : DC brushless servo motor provides years of quiet and reliable operation.

Meticulous Craftsmanship with Exquisite Elegance

The simple and slim appearance of GR-512 presents outstanding ambience with designer's creativity and craftsmen's expertise. The polished cabinet shines with luxury and attracts everyone's attention.

GR-512 Speed Gate is set up at entrance and exit of passage area. The system can be connected with recognition system, surveillance system, coin acceptor, card reader and ticket validation system. Uni-directional, bi-directional and no passage modules can be selected by remote control. If passengers are recognized, panel will open speedily. One person is allowed to pass each time. System alarm will out put when sensors detect tailgating.

GR-512 is suitable for an area of high-volume pedestrian access and high security control requirements, such as stations, airport, corporate headquarters, business buildings, etc. It enhances the effect of automatic unmanned management and raises the whole quality of the site.

GR-512/ GR-512W

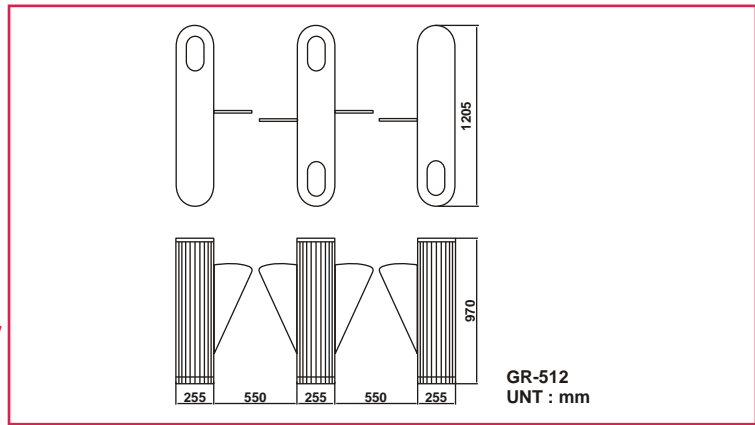

Reasonable Design

- 550mm wide passages are comfortable and ergonomic.
- By using GR512W, its 900mm wide walkway complied with disability discrimination requirements.
- Recognition system, such as card readers and ticket validators, can be hidden by and installed in the cabinet.
- Inner circuit adopts DC 24V and DC 12V to drive and control for safety.
- Built-in 8-digit counter can display passage records.
- Function setting by parameters is highly adaptive to different environments.
- Stainless steel structure a stable environment for GR-512. Our design can reduce the vibration and metal fatigue, and also rising machine's efficiency and long life cycle.
- Cabinet with 1.5mm thickness, SUS-304 brushed stainless steel or coating.
- 12mm transparent high-strength and impact resistant panel.
- High brightness LED light embedded panel emitting red and green back lights to enhance guidance for passengers. (option)

Outstanding Features

- Panel's open or close movement can automatically self-correct at the same time.
- GR-512 can adjust panel's open or close speed by parameters setting. (From 0.5 to 2 seconds)
- Output torsion of panel can be adjusted and anti-trap safety detection is available.
- GR-512 can withstand 100% continuous full-time frequent operation.
- System can self-detect errors all the time. Alert system will send an error message to central when system is in an error status.
- Panel will automatically open for emergency or power outage. (Option)
- Current Consumption: Maximum 2.0A / AC 220V

Motor Design

- High performance and stable DC brushless servo motor suitable for long-term continuous operation without temperature rises.
- DC brushless servo controller can digitalize power output. We use this advantage to set up speed and torsion for open / close panel.
- Motor controller with movement coding monitor can detect extraordinary external force. System will stop power output to prevent damage.

Digital Control

- Built-in controller with entry, exit, and bi-directional modes.
- We design different function dry contacts on our control panel for various type of space.
- System with the function of warning, detection, Protection and anti-noise.
- DC 12V Logic Voltage.
- Anti-tailgating and reverse intruding detection.
- Memorizing continuous open panel signal input setting
- Panel automatically close after timeout period of 1~30 secs by setting
- 6+ set logic photocells detection.

LED Traffic Light, LED Passage Light and Voice Alarm

- LED Traffic Light : Passage is allowed when the light turns green, and no passage is permitted when the light turns red.
- LED Passage Light : GR-512 can use LED light to show people the messages : insert your card, stop reading cards, and successful.
- Voice alarm will urge people safely pass through before time is up.

Standards

- Operating Temperature: 0~45°C
- Relative Humidity: 0~85%
- Weight: 75 KGS
- Power: AC110 / 220V, 50 / 60Hz, 1PH
- Photocells: 6PCS
- Quality Certification: ISO 9001 / CE
- Dimension: 1205(L) × 255/435(W) × 970(H)mm

Input and Output

- Entry / exit direction input
- Open status input
- Compelling open signal input
- Fire alarm input
- Passage completion output
- Error status alert
- Tailgating alert
- Reverse intruding alert

Remote Control

- RS-485 Interface
- TCP / IP network remote control allows changes of remote control modes and panels opening settings. (Option)
- Remote control box. (Option)

Reliability

- Modular Design : GR-512 is easy to repair and maintain
- MCBF: _ 1,500,000 Cycles
- MTTR: _ 30 mins

Shlara Automation Private Limited

Regd. Off | Old No : 513, New No : 5, 1st West Street, Kamaraj Nagar, Thiruvanniyur, Chennai - 600 041. Tamilnadu, INDIA
Sales. Off | Old No : 11, New No : 19, Venkataraman Street, Bishop Garden's Extension, R.A. Puram, Chennai - 600 028. Tamilnadu, INDIA

+91 98402 94082 | Info@ShlaraAutomation.Com | www.shlaraautomation.com